

SIZE: 1/2" - 6"

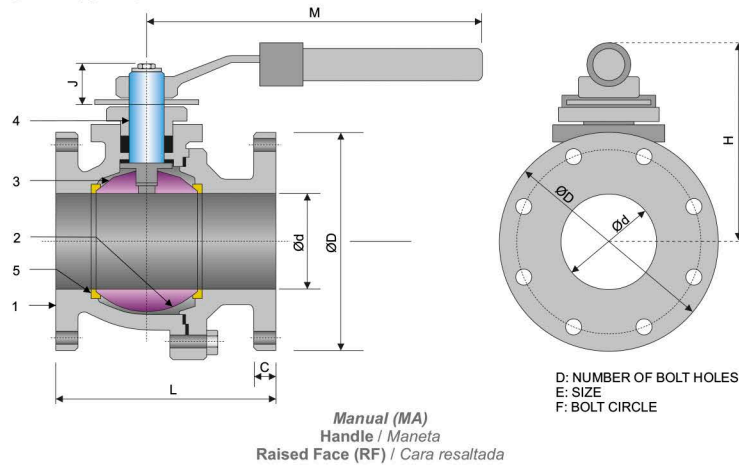

SIZE: 8"

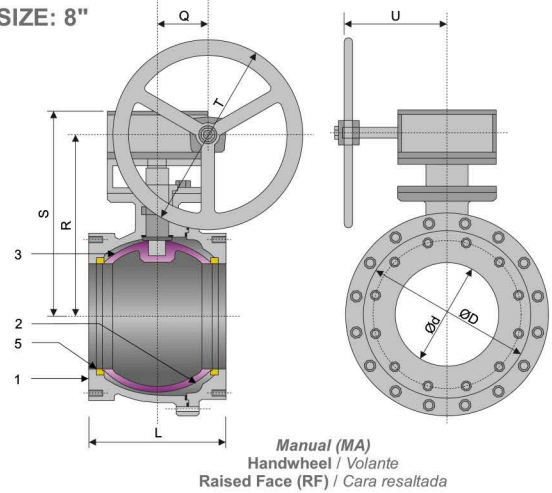

SPECIFICATIONS / Especificaciones

ASME

DESIGN Diseño	CONNECTION END / Extremos	SIZES Rango
	FLANGED Bridada	
ASME B16.10 MSS SP-72	EN1092-2	1/2" - 8"

MAIN PARTS MATERIAL / Material de las piezas principales

Nº	PART NAME Nombre de pieza	CAST IRON Hierro fundido
1	Body / Cuerpo	CAST IRON / Hierro fundido GG25
2	Body end / Extremo del cuerpo	CAST IRON / Hierro fundido GG25
3	Ball / Bola	CAST IRON / Hierro fundido GG25
4	Stem / Vástago	BRASS / Latón - CW614N UNI EN12164
5	Seat / Asiento	PTFE + GRAPHITE / Grafito

MAIN EXTERNAL DIMENSIONS / Dimensiones externas principales

ASTM A 126 Class B (NPS 1/2" - 8")

NPS (in.)	Ød	ØD	L	M	H	C	D	E	F	J	Q	R	S	T	U	W / P (Kg.)
1/2"	15	90	108	229	89	-	4	-	-	-	-	-	-	-	-	2,72
3/4"	20	95	118	229	89	-	4	-	-	-	-	-	-	-	-	3,63
1	25	110	127	229	102	-	4	-	-	-	-	-	-	-	-	4,55
1 1/2"	40	127	165	279	127	-	4	-	-	-	-	-	-	-	-	7,26
2"	50	152	178	279	127	16	4	19	125	25	-	-	-	-	-	9,98
2 1/2"	63	178	190	419	146	19	4	19	140	25	-	-	-	-	-	15,42
3"	76	190	204	419	159	21	4	19	153	25	-	-	-	-	-	17,24
4"	95	229	229	460	178	23	8	19	191	25	-	-	-	-	-	26,31
6"	145	280	267	552	254	25	8	21	242	43	-	-	-	-	-	53,50
8"	205	343	292	-	350	-	8	-	300	-	123	377	436	458	247	156,50

Notes / Notas:

- Approximate weights / Pesos aproximados.
- Larger diameters on request / Diámetros superiores bajo petición.
- Other material on request / Otros materiales bajo petición.

UNITS / Unidades mm